

KENWOOD

AV SURROUND PROCESSOR

SS-992

INSTRUCTION MANUAL

KENWOOD CORPORATION

Introduction

Your choice of this product indicates that you are a devotee to excellence in sound reproduction.

We appreciate your patronage and take pride in the long tradition of quality components that our company represents.

So that you can get the most out of your unit, we suggest that you take the time to read through this manual before you hook up and operate your system. This will acquaint you with operating features and system-connection considerations so that your listening pleasure will be enhanced right from the start. You will notice that in all aspects of planning, engineering, styling, operating convenience and adaptability we have sought to anticipate your needs and desires.

Keep this manual handy for future reference.

For your records

Record the serial number, found on the back of the unit, in the spaces designated on the warranty card, and in the space provided below. Refer to the model and serial numbers whenever you call upon your dealer for information or service on this product.

Model _____ Serial Number _____

Unpacking

Unpack the unit carefully and make sure that all accessories are put aside so they will not be lost.

Examine the unit for any possibility of shipping damage. If your unit is damaged or fails to operate, notify your dealer immediately. If your unit was shipped to you directly, notify the shipping company without delay. Only the consignee (the person or company receiving the unit) can file a claim against the carrier for shipping damage.

We recommend that you retain the original carton and packing materials for use should you transport or ship the unit in the future.

Manufactured under license from Dolby Laboratories Licensing Corporation. Additionally licensed under one or more of the following patents : U.S. numbers 3,632,886, 3,746,792 and 3,959,590 ; Canadian numbers 1,004,603 and 1,037,877. "Dolby" and the double-D symbol  are trademarks of Dolby Laboratories Licensing Corporation.

Accessories

Audio cord 2 System control cord 1

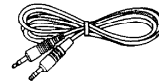







AC plug adaptor 1
(except for some areas)
For the unit with a European
AC plug in areas other than
Europe . .



Contents

Caution : Read the pages marked  carefully to ensure safe operation.

Introduction	2	Speaker arrangements	9
 Before applying power	3	Dolby Surround field adjustment (DOLBY PRO LOGIC)	10
 Safety precautions	3	Operation of Dolby Surround playback (DOLBY PRO LOGIC)	11
 IMPORTANT SAFEGUARDS	4	 3 STEREO adjustment	12
System connections	6	 3 STEREO playback	12
Connection with KA-892, KA-893, KC-992 or KC-993	6	HALL/THEATER Surround Play	13
Connection with an ordinary amplifier or receiver	7	In case of difficulty	14
Controls and indicators	8	 Specifications	15
Operating instructions	9		
Main features	9		

⚠ Caution: Read this page carefully to ensure safe operation.

Before applying power

For the U.S.A. and Canada

Important!

Units shipped to the U.S.A. and Canada are designed for operation on 120 volts AC only.

CAUTION: TO PREVENT ELECTRIC SHOCK DO NOT USE THE AC PLUG WITH AN EXTENSION CORD, RECEPTACLE OR OTHER OUTLET UNLESS THE BLADES CAN BE FULLY INSERTED TO PREVENT BLADE EXPOSURE.

For the United Kingdom

Important!

Units shipped to the U.K. are designed for operation on 240 volts AC only.

The mains plug must be removed from the wall socket prior to any internal examination.

The wires in this mains lead are coloured in accordance with the following code:

Blue Neutral
Brown Live

The wires in this mains lead must be connected to the terminals in the plug as follows:

Wire colour	Plug terminal marking
Blue	N or Black
Brown	L or Red

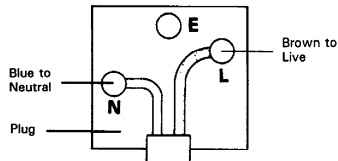

Notes:

1. If a 13-amp plug is used, this must be fitted with a 5-amp fuse.
2. If a 3-pin plug with earthing contact is used, no wire must be connected to the E terminal.

For Australia and Europe

Important!

Units shipped to Australia are designed for operation on 240 V AC only.

Units shipped to Europe are designed for operation on 230 V AC only.

For other countries

Important!

Units shipped to countries other than the above countries are equipped with an AC voltage selector switch on the rear panel. Refer to the following paragraph for the proper setting of this switch.

AC voltage selection

This unit operates on 110-120 or 220-240 volts AC. The AC voltage selector switch Type A or Type B on the rear panel is set to the voltage that prevails in the area to which the unit is shipped. Before connecting the power cord to your AC outlet, make sure that the setting position of this switch matches your line voltage. If not, it must be set to your voltage in accordance with the following direction.

Note:

Our warranty does not cover damage caused by excessive line voltage due to improper setting of the AC voltage selector switch.

AC voltage selector switch

Type A

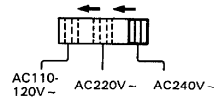



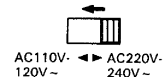

Type B



Move switch lever to match your line voltage with a small screwdriver or other pointed tool.

Safety precautions

WARNING: TO PREVENT FIRE OR ELECTRIC SHOCK, DO NOT EXPOSE THIS APPLIANCE TO RAIN OR MOISTURE.

 <p>CAUTION RISK OF ELECTRIC SHOCK DO NOT OPEN</p> 	<p>CAUTION: TO REDUCE THE RISK OF ELECTRIC SHOCK, DO NOT REMOVE COVER (OR BACK). NO USER-SERVICEABLE PARTS INSIDE, REFER SERVICING TO QUALIFIED SERVICE PERSONNEL.</p>
	<p>THE LIGHTNING FLASH WITH ARROWHEAD SYMBOL, WITHIN AN EQUILATERAL TRIANGLE, IS INTENDED TO ALERT THE USER TO THE PRESENCE OF UNINSULATED "DANGEROUS VOLTAGE" WITHIN THE PRODUCT'S ENCLOSURE THAT MAY BE OF SUFFICIENT MAGNITUDE TO CONSTITUTE A RISK OF ELECTRIC SHOCK TO PERSONS.</p>
	<p>THE EXCLAMATION POINT WITHIN AN EQUILATERAL TRIANGLE IS INTENDED TO ALERT THE USER TO THE PRESENCE OF IMPORTANT OPERATING AND MAINTENANCE (SERVICING) INSTRUCTIONS IN THE LITERATURE ACCOMPANYING THE APPLIANCE.</p>

IMPORTANT SAFEGUARDS

⚠ Caution : Read this page carefully to ensure safe operation.

Please read all of the safety and operating instructions before operating this unit. For best results, follow all warnings placed on the unit and adhere to the operating and use instructions. These safety and operating instructions should be retained for future reference.

1. Power sources — The unit should be connected to a power supply only of the type described in the operating instructions or as marked on the appliance.

2. Power-cord protection — Power-supply cords should be routed so that they are not likely to be walked on or pinched by items placed upon or against them, pay particular attention to cords at plugs, convenience receptacles, and the point where they exit from the unit.

Never pull or stretch the cord.



3. Grounding or polarization — The precautions should be taken so that the grounding or polarization means of this unit is not defeated.

4. Ventilation — The unit should be situated so that its location or position does not interfere with its proper ventilation.

To maintain good ventilation, do not put records or a table-cloth on the unit. Place the unit at least 10 cm away from the walls.

Do not use the unit on a bed, sofa, rug or similar surface that may block the ventilation openings.



5. Water and moisture — The unit should not be used near water — for example, near a bathtub, washbowl, kitchen sink, laundry tub, in a wet basement, or near a swimming pool, etc.

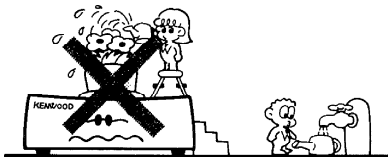

6. Temperature — The unit may not function properly if used at extremely low, or freezing temperatures. The ideal ambient temperature is above +5°C (41°F).

7. Heat — The unit should be situated away from heat sources such as radiators, heat registers, stoves, or other units (including amplifiers) that produce heat.

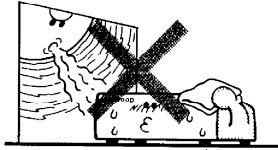

8. Electric shock — Care should be taken so that objects do not fall and liquid is not spilled into the enclosure through openings. If a metal object, such as a hair pin or a needle, comes into contact with the inside of this unit, a dangerous electric shock may result. For families with children, never permit children to put anything, especially metal, inside this unit.



9. Enclosure removal — Never remove the enclosure. If the internal parts are touched accidentally, a serious electric shock might occur.

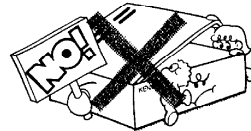

10. Magnetic fields — Keep the unit away from sources of magnetic fields such as TV sets, speaker systems, radios, motorized toys or magnetized objects.

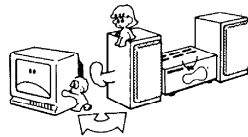

11. Cleaning — Do not use volatile solvents such as alcohol, paint thinner, gasoline, or benzine, etc. to clean the cabinet. Use a clean dry cloth.

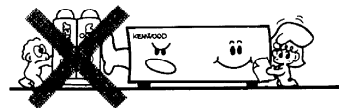

⚠ Caution : Read this page carefully to ensure safe operation.

12. Carts and stands — An appliance and cart combination should be moved with care. Quick stops, excessive force, and uneven surfaces may cause the appliance and cart combination to overturn.



13. Nonuse periods — The power cord of the unit should be unplugged from the outlet when left unused for a long period of time.

14. Abnormal smell — If an abnormal smell or smoke is detected, immediately turn the power OFF and pull out the power cord. Contact your dealer or nearest service center.

POWER OFF!

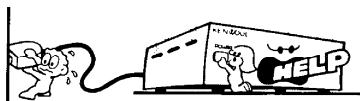

15. Damage requiring service — The unit should be serviced by qualified service personnel when:

- A. The power-supply cord or the plug has been damaged; or
- B. Objects have fallen, or liquid has been spilled into the unit; or
- C. The unit has been exposed to rain; or
- D. The unit does not appear to operate normally or exhibits a marked change in performance; or
- E. The unit has been dropped, or the enclosure damaged.

16. Servicing — The user should not attempt to service the unit beyond that described in the operating instructions. All other servicing should be referred to qualified service personnel.

17. Outdoor antenna grounding — If an outside antenna is connected to the receiver, be sure the antenna system is grounded so as to provide some protection against voltage surges and built up static charges. Section 810 of the National Electrical Code, ANSI/NFPA 70, provides information with respect to proper grounding of the mast and supporting structure, grounding of the lead-in wire to an antenna discharge unit, size of grounding con-

ductors, location of antenna-discharge unit, connection to grounding electrodes, and requirements for the grounding electrode. See Figure.

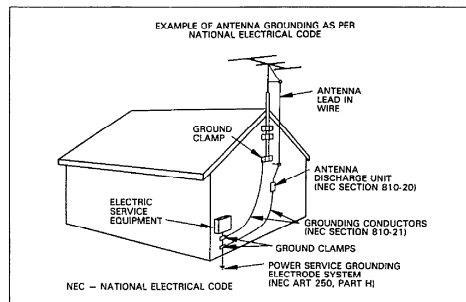

18. Power lines — An outdoor antenna should be located away from power lines.

19. AC outlets — Do not connect other audio equipment with a power consumption larger than that specified to the AC outlet on the rear panel. Never connect other electrical units, such as an iron or toaster, to it to prevent fire or electric shock.

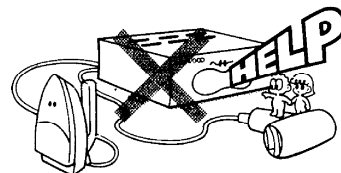

Notes:

- 1. Item 3 is not required except for grounded or polarized equipment.
- 2. Item 17 and 18 are not required except for units provided with antenna terminals.
- 3. Item 17 complies with UL in the U.S.A.

System connections

Make connections as shown below. When connecting the related system components, refer also to the instruction manuals of the related components.

Do not plug in the power lead until all connections are completed.

■ Connection with KA-892, KA-893, KC-992 or KC-993

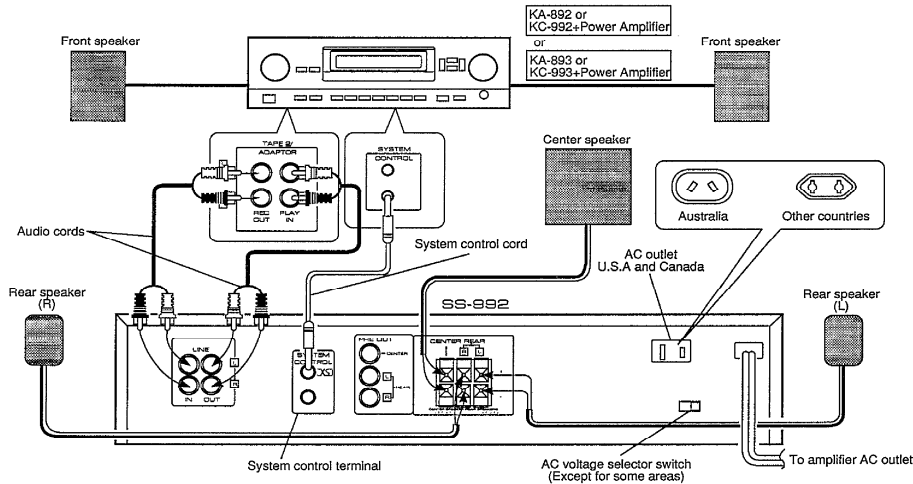

System control connection

- Be sure to insert the system control cord plugs fully into the SYSTEM CONTROL terminals.
- If the system control cord and audio cords are not connected properly, the automatic system governing remote control and system functions will not operate.

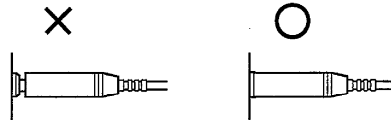

Preparations for operation A:

When this unit is connected to the TAPE 2/ADAPTOR jacks of the amplifier KA-892, KA-893, KC-992 or KC-993

- ① Set the switch on the amplifier rear panel to ADAPTOR. (The switch position should be changed while the power is OFF.)
- ② Turn the powers of the components to ON.
- ③ Press the TAPE 2/ADAPTOR key on the amplifier front panel so that [ADAPTOR] lights up.



- The VOLUME CONTROL of the amplifier is set automatically to the center position in about 20 seconds. The keys are invalid in this period.
- The overall volume is to be adjusted with the VOLUME CONTROL of this unit or with the remote control provided with the amplifier.
- When this unit is not to be used, press the TAPE 2/ADAPTOR key on the amplifier front panel so that [ADAPTOR] goes out.

Notes:

1. Connect all cords firmly. If connections are loose, there could be loss of sound or noise produced.
2. When plugging and unplugging connection cords, be sure to first remove the power cord from the AC outlet. Plugging/unplugging connection cords without removal of the power cord can cause malfunctions or damage to the unit.
3. Do not connect up a power source which is larger than that indicated on the socket at the rear of the unit.

■ **Connection with an ordinary amplifier or receiver other than KA-892, KA-893, KC-992 or KC-993**

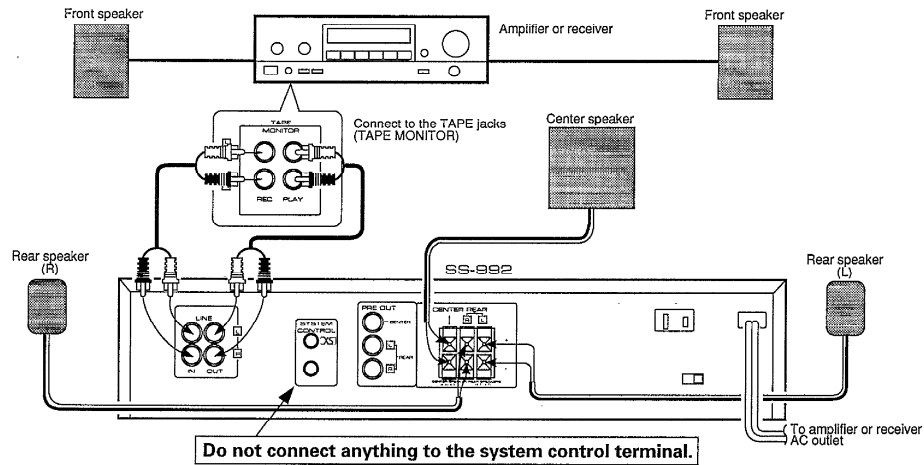

Preparations for operation B:

When this unit is connected to an ordinary amplifier or receiver

- ① Turn the powers of the components to ON.
- ② Set the TAPE MONITOR switch of the amplifier or receiver to the monitoring (ON) position.
- ③ Set the volume control of the amplifier or receiver to around the center position.
 - The overall volume is to be adjusted with the VOLUME CONTROL of this unit.

Speaker connections

- ① Remove insulation.
- ② Twist wire tightly.
- ③ Push the lever.
- ④ Insert the wire.
- ⑤ Return the lever.

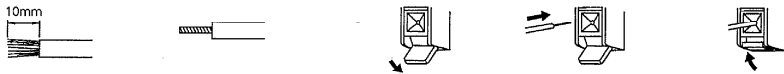

- Connect speakers rated at 8 ohm or more to the SPEAKERS terminals.
- Never short-circuit the + and - speaker cords.
- If the left and right speakers are connected inversely or if the speaker cords are connected with reversed polarity, the sound becomes unnatural with ambiguous acoustic image positioning. Be sure to connect the speakers and speaker cords correctly.

Connection of PRE OUT jacks

Sound will not be output from the speakers if they are connected directly to the PRE OUT jacks. The output from these jacks should be connected to speakers with built-in amplifier or to exclusive amplifiers to which the speakers are connected.

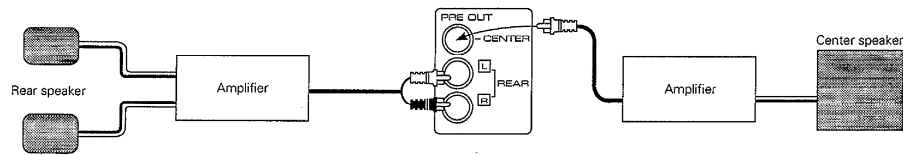

- Use these jacks if you want to listen to the speakers with larger volumes or with different tones.

Controls and indicators

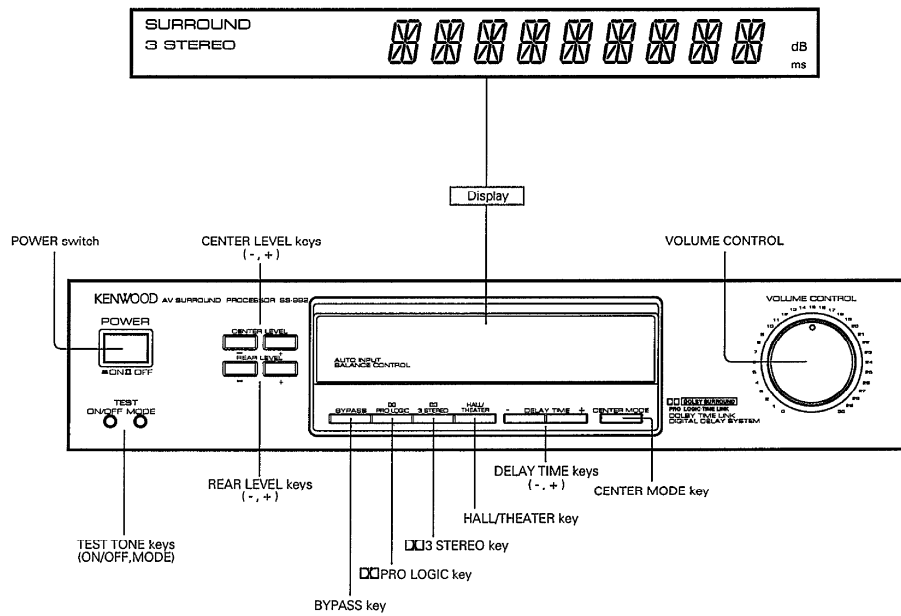

Operating instructions

■ Main features

This system incorporates the following Surround functions which can provide the feeling of presence in a concert hall or theater or the powerful effects of theater movies recorded with Dolby Surround audio.

1. **PRO LOGIC** : When video software carrying "DOLBY SURROUND" mark is played, this mode provides the similar Dolby Surround effect to movie theaters.
2. **3 STEREO** : The Dolby 3 Stereo mode uses an additional center speaker to improve the positioning of words, etc., when playing video software such as a movie in your home.
3. **HALL/THEATER** : **HALL**A powerful sound effect, as if the listener is in a concert hall, can be obtained. **THEATER**A natural reverberation effect, like when viewing a movie in a movie theater, can be obtained with sources which are not recorded with Dolby Surround.

■ Speaker arrangements

Surround (rear) speakers can be placed with various arrangements according to the listening room size and its reverberation characteristics. The example shown in the illustration is a typical example among several arrangements which allow efficient enjoyment of Surround effects. In addition to it, other arrangements are also possible. Please install the rear speakers according to your individual taste as well as to the listening room.

Standard layout

DOLBY PRO LOGIC mode (NORMAL/WIDEBAND)

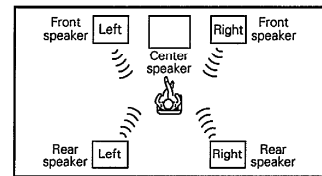

When the rear speakers are not used

DOLBY 3 STEREO mode

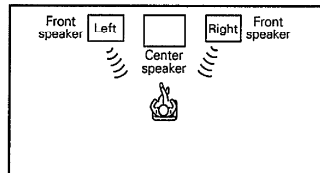

When the center speaker is not used

DOLBY PRO LOGIC mode (PHANTOM), HALL/THEATER

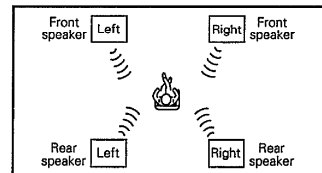

Delay time

As shown in the example of illustration, the sound of piano played on the stage attains the ears of listener as a synthesis of the direct sound from piano, the indirect sounds which are reflected once or twice by the reflectors, ceiling and side and back walls, and the reverberation sounds which repeat infinite reflections until they fade out completely.

The indirect sounds always pass through longer routes compared to the direct sound. The delay between the direct and indirect sounds is called the DELAY TIME, and the level of the indirect or reverberated sounds is called the PRESENCE LEVEL.

The indirect sounds accompanied with delay play a very important role in providing better sound effects and the feeling of presence of concert halls, etc. The acoustic field also varies depending on the speaker arrangement. It is recommended to try various delay time setting to obtain the best sound field possible.

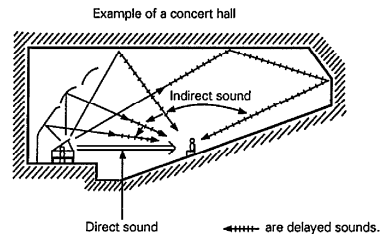

■ Dolby Surround field adjustment (DOLBY PRO LOGIC)

Preparations : Complete the "Preparations of operation A or B" on page 6 or 7 before proceeding to the following.

1 Set the Dolby Surround mode.

Light up
 Main unit

Remote control unit provided with amplifier
 Every time the key is pressed, the surround mode is switched.
 DOLBY SURROUND → DOLBY 3 STEREO → HALL → THEATER

2 Adjust the volume balance.

- Repeat steps ① and ②, and adjust so that the test tone volumes are the same on all speakers.
- The level being adjusted is displayed.

2 Select the center mode.

Every time the key is pressed, the center mode is switched.
 NORMAL → WIDEBAND → PHANTOM

- Refer to column "Center mode" below.

5 Stop generating the test tone.



3 Turn on the test tone.



4 Adjust the volume balance.

① Press the MODE key.

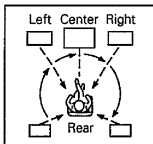

- Every time the key is pressed, the speaker generating the noisy test tone is changed. (Holding the key depressed moves the test tone automatically every 2 seconds.)

In NORMAL or WIDEBAND mode :

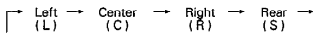

In PHANTOM mode :

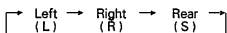

6 Set the delay time.

To decrease To increase

- Calculate the proper delay time for Dolby Surround by referring to the illustration below.
- The delay time can be adjusted in the range from 15 to 30 ms.
- Once a delay time is set, it is automatically held in memory so the same delay time is displayed whenever Dolby Surround is switched ON later.

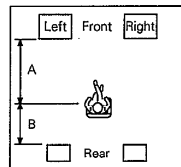

$$\text{Delay time (ms)} = 20\text{ms} + 3\text{ms} (A - B)$$

A : Distance of front speaker (m)
B : Distance of rear speaker (m)

Center mode

Select one of the following center modes according to the type of the presence speakers in your system.

NORMAL : Use this mode with a center speaker of a compact size.

WIDEBAND : Use this mode with a center speaker of a medium or larger size.

- If you cannot identify whether your center speaker is of the medium or compact size, try both the NORMAL and WIDEBAND mode and use the one that can provide better sound positioning.

PHANTOM : Use this mode when the center speaker is not used.

- Even without the center speaker, the signal is processed in a simulated manner to ensure proper center image positioning and provide the enjoyment of Dolby Surround.

■ Operation of Dolby Surround playback (DOLBY PRO LOGIC)

When video software carrying "DD [DOLBY SURROUND]" mark is played, this mode provides the similar Dolby Surround effect to movie theaters.

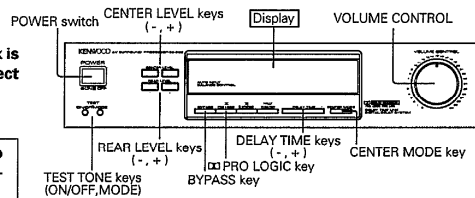

Before using the Dolby PRO LOGIC mode, be sure to perform the "Dolby Surround field adjustment" procedure.

1 Set the Dolby Surround mode.

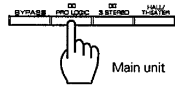

Remote control unit provided with amplifier

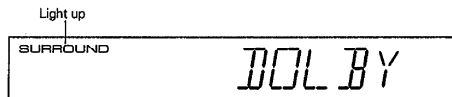

Every time the key is pressed, the surround mode is switched.



2 Check the center mode.

- Normally, the last mode used is held in memory. If it is different from the required mode, select the mode which was used in step 2 of the "Dolby Surround field adjustment" (page 10).

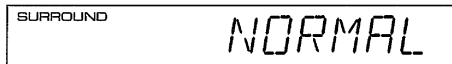

Every time the key is pressed, the center mode is switched.

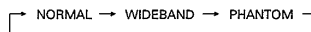

3 Play a software program encoded with Dolby Surround.

4 Adjust the volume.

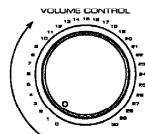

Adjusts the overall volume.

- When the level balance of center and rear speakers is not good, perform the "Dolby Surround field adjustment" procedure again.

To return to normal stereo playback.

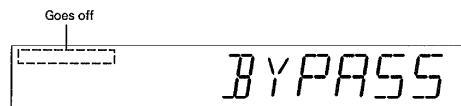
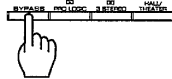

Operating instructions

The Dolby 3 Stereo mode uses an additional center speaker to improve the positioning of words, etc., when playing video software such as a movie in your home.

■ 3 STEREO adjustment

Preparations: Complete the "Preparations of operation A or B" on page 6 or 7 before proceeding to the following.

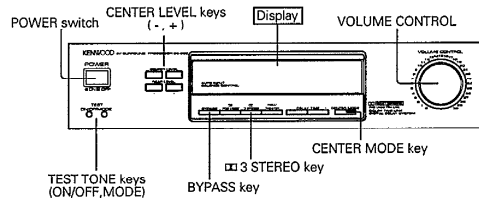

■ 3 STEREO playback

1 Set the 3 STEREO mode.

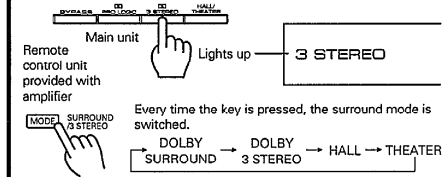

2 Select the center mode.

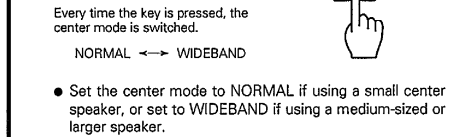

3 Turn on the test tone.



4 Adjust the center speaker volume.

① Press the MODE key.

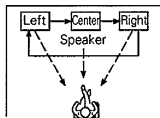

- Every time the key is pressed, the speaker generating the noisy test tone is changed. (Holding the key depressed moves the test tone automatically every 2 seconds.)

② Adjust the volume.



- Repeat steps ① and ②, and adjust so that the level of the center speaker is equal to that of the left and right speakers.

5 Stop generating the test tone.

Press the TEST TONE ON/OFF key.



1 Set the 3 STEREO mode.

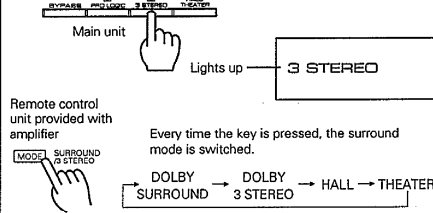

2 Check the center mode.



- Normally, the last mode used is held in memory. If it is different from the required mode, select the mode which was used in step 2 of the "3 STEREO adjustment".

3 Play a stereo software program or a Dolby surround program.

4 Adjust the volume.

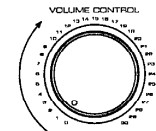

Adjusts the overall volume.

To return to normal stereo playback

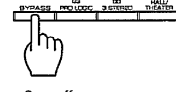

Goes off

BYPASS

■ HALL/THEATER Surround play

Preparations : Complete the "Preparations of operation A or B" on page 6 or 7 before proceeding to the following.

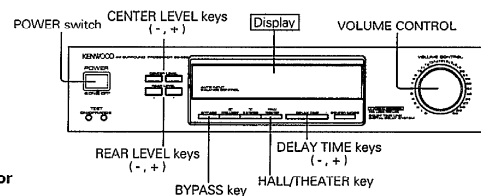

1 Select the Surround mode.

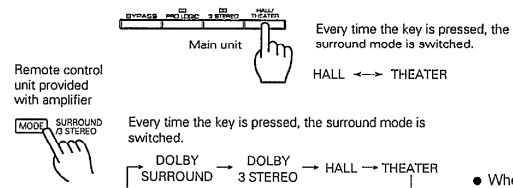

HALL

- When a source is played in monaural, select "HALL".

2 Set the delay time.

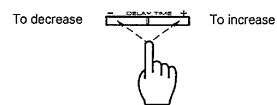

DELAY 20 ms

- The delay time can be adjusted in the range from 2 to 30 ms.
- The delay time is displayed when the DELAY TIME key is pressed. It can be adjusted in 1.0 ms step every time the key is pressed.
- When the delay time is decreased : An atmosphere of a small hall, for example a jazz club, can be obtained.
- When the delay time is increased : An atmosphere of a large hall, for example a concert hall, can be obtained.

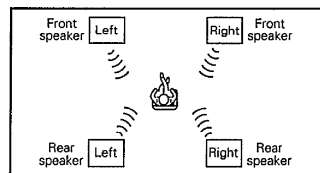

3 Play a music source.

- 1 Play a music source.
- 2 Adjust the listening volume.
- 3 Adjust the rear speaker volume.

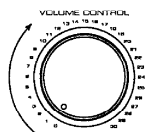

Adjusts the overall volume.



REAR -- 10 dB

To return to normal stereo playback from Surround playback

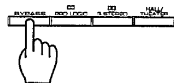

BYPASS

In case of difficulty

What appears to be a malfunction may not always be serious. If your unit should not perform as expected, consult the table below to see if the problem can be corrected before seeking help from your dealer or service representative.

Symptom	Cause	Remedy
Sound is not output.	<ul style="list-style-type: none"> ● The speaker cords are disconnected. ● The VOLUME is set to the minimum position. ● The audio cords are disconnected. 	<ul style="list-style-type: none"> ● Connect them properly referring to "System connections". ● Adjust the volume to a proper level. ● Check the audio cords connections.
Sound is not output from the Surround rear speaker and/or their sound is very small.	<ul style="list-style-type: none"> ● The rear-speaker cords are disconnected. ● The REAR LEVEL is set to the minimum level. ● The BYPASS mode has been set. Or the Dolby 3 STEREO mode has been selected. ● The audio source is monaural. (When the audio source is monaural, sound is not output from the rear speakers when the unit is set to the DOLBY SURROUND or THEATER surround position.) ● The TAPE 2/ADAPTOR key on the amplifier (KA-892, KA-893, KC-992 or KC-993) front panel is not depressed. 	<ul style="list-style-type: none"> ● Connect them properly referring to "System connections". ● Adjust the REAR LEVEL controls. ● Select a Surround mode (DOLBY SURROUND, HALL or THEATER). ● Set the surround position to HALL. ● Press the TAPE 2/ADAPTOR key so that [ADAPTOR] lights up.
Remote control unit provided with the amplifier (KA-892, KA-893, KC-992 or KC-993) cannot be used.	<ul style="list-style-type: none"> ● The TAPE 2/ADAPTOR switch on the amplifier rear panel is set to TAPE. ● The system control cords are disconnected. 	<ul style="list-style-type: none"> ● Set to ADAPTOR. ● Connect them properly referring to "System connections".

Notes:

1. This system is microprocessor-controlled, so malfunction may occur due to external noise or interference noise. In such a case, unplug the power cord, plug it and turn power on again.
2. Do not use contact cleaners because it could cause a malfunction. Be specially careful against contact cleaners containing oil, for they may deform the plastic components.

Specifications

⚠ **Caution : Read this page carefully to ensure safe operation.**

Power Output

Continuous Rated Power Output (FTC)

Center

35 watts minimum RMS, at 8 Ω, 1 kHz with no more than 0.9% total harmonic distortion

Rear

15 watts per channel minimum RMS, both channels driven, at 8 Ω, 1 kHz with no more than 0.9% total harmonic distortion

Total harmonic distortion

Center 0.08 % (1 kHz, 17.5 W, 8 Ω)

Rear 0.08 % (1 kHz, 7.5 W + 7.5 W, 8 Ω)

Frequency Response

(LINE OUT) 10 Hz ~ 40 kHz, 0 dB, -3 dB

Signal to Noise Ratio

(LINE OUT) 95 dB (IHF A)

Input Sensitivity/Impedance

..... 200 mV/47 kΩ

Output Level/Impedance

LINE OUT 1 V/2.2 kΩ

PRE OUT 1 V/2.2 kΩ

General

Power Consumption 90 W

AC Outlet (UNSWITCHED)

For the U.S.A. and Canada 1 (25 W, 0.2 A max.)

For other countries 1 (25 W max.)

Dimensions

W : 440 mm (17 - 5/16")

H : 99 mm (3 - 7/ 8")

D : 285 mm (11 - 1/ 4")

Weight (net)

..... 5.6 kg (12.3 lb)

Note:

KENWOOD follows a policy of continuous advancements in development. For this reason specifications may be changed without notice.

For CANADA

DOC REGULATION

"This digital apparatus does not exceed the CLASS B limits for radio noise emissions from digital apparatus as set out in the radio interference regulations of the Canadian Department of Communications."

For the U.S.A.

FCC WARNING:

This equipment may generate or use radio frequency energy. Changes or modifications to this equipment may cause harmful interference unless the modifications are expressly approved in the instruction manual. The user could lose the authority to operate this equipment if an unauthorized change or modification is made.

NOTE:

This equipment has been tested and found to comply with the limits for a Class B digital device, pursuant to Part 15 of the FCC Rules.

These limits are designed to provide reasonable protection against harmful interference in a residential installation. This equipment may cause harmful interference to radio communications, if it is not installed and used in accordance with the instructions. However, there is no guarantee that interference will not occur in a particular installation. If this equipment does cause harmful interference to radio or television reception, which can be determined by turning the equipment off and on, the user is encouraged to try to correct the interference by one or more of the following measures:

- — Reorient or relocate the receiving antenna.
- — Increase the separation between the equipment and receiver.
- — Connect the equipment into an outlet on a circuit different from that to which the receiver is connected.
- — Consult the dealer or an experienced radio/TV technician for help.

KENWOOD